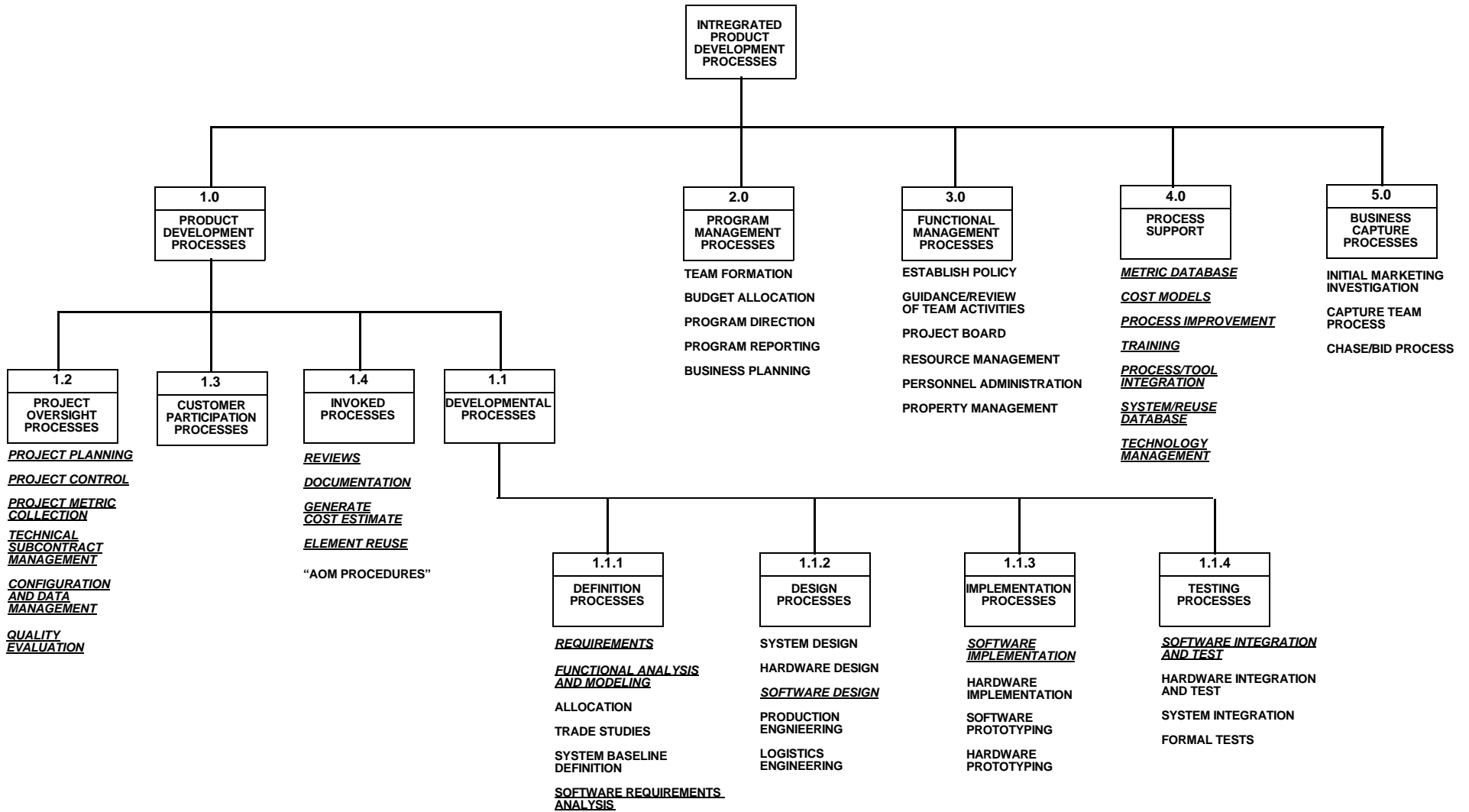

FIGURE 1

- o **Charter covers all of Engineering.**
- o **Embodies Key precepts:**
 - **Design-to-cost**
 - **Integrated Product Development**
 - **Reuse**
 - **Customer focus**
 - **Risk Management**
- o **Team centered organization.**
- o **Responds to many different initiatives:**
 - **TQM**
 - **SEI**
 - **DOD-STD-2167a-8**
 - **Air Force SDIP**
 - **DPRO process focus**

AM&ASD Process Hierarchy



SOFTWARE ELEMENTS OF THE PROCESS IDENTIFIED

FIGURE 2

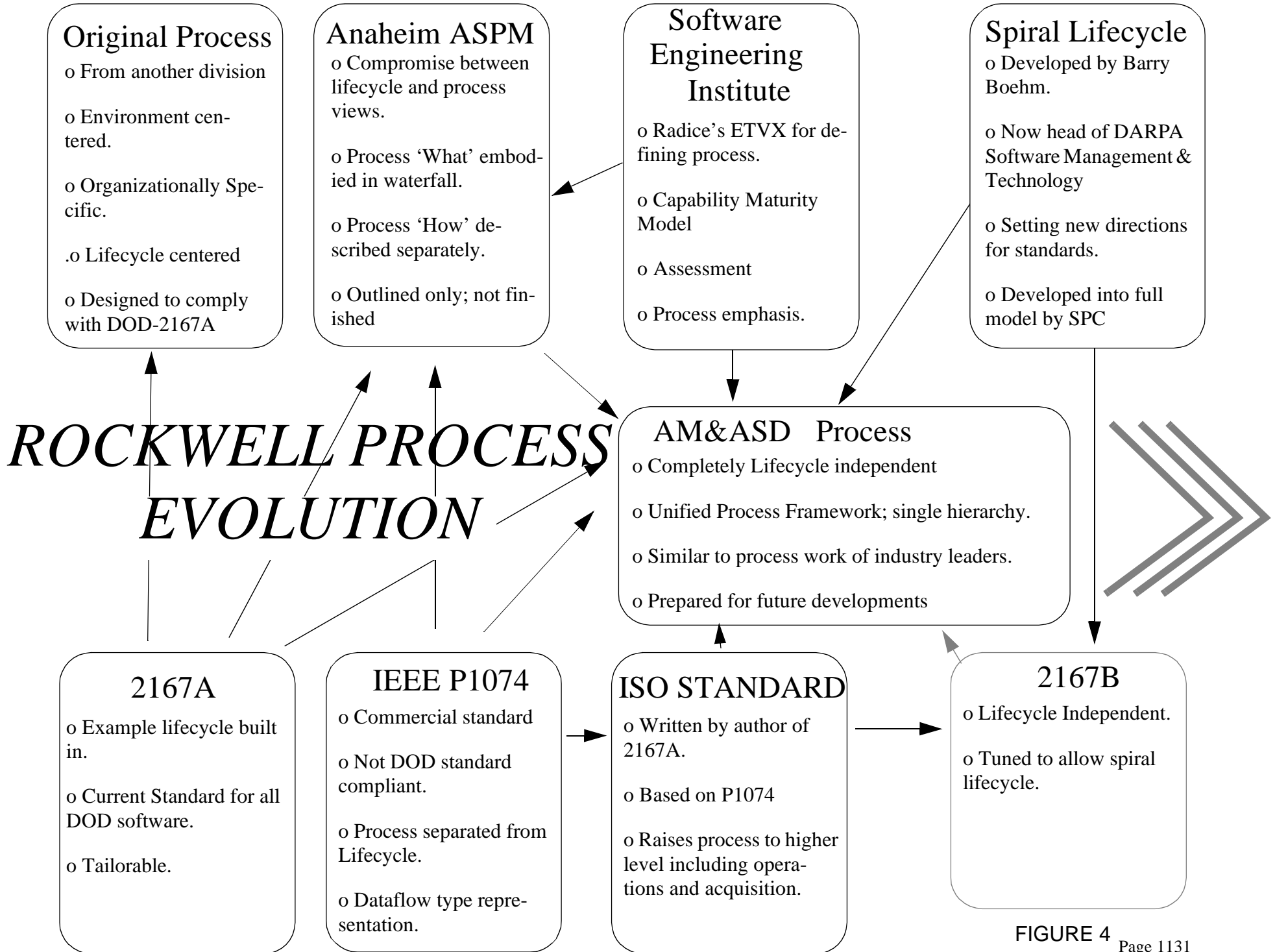
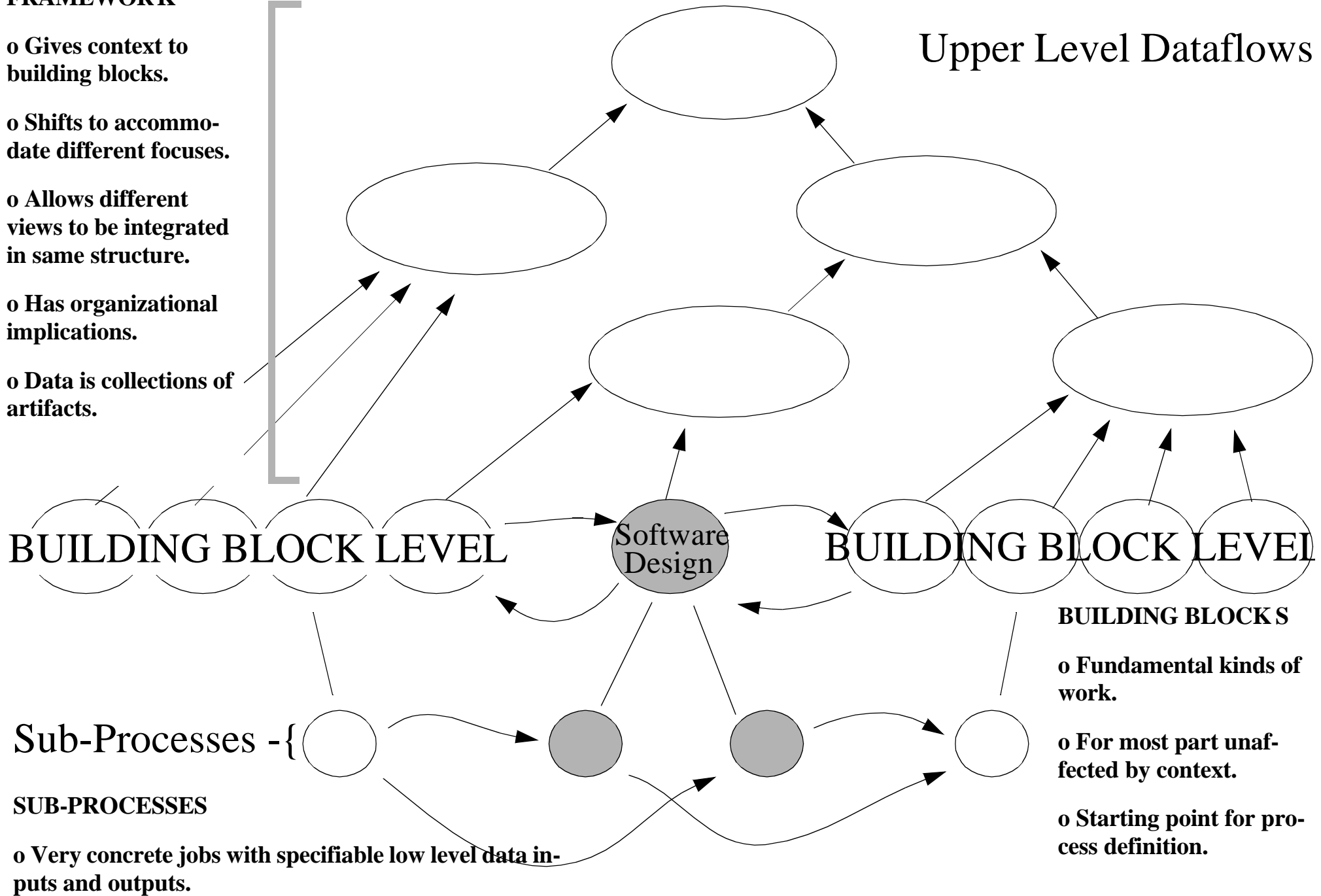

FIGURE 4 Page 1131

FRAMEWORK

- o Gives context to building blocks.
- o Shifts to accommodate different focuses.
- o Allows different views to be integrated in same structure.
- o Has organizational implications.
- o Data is collections of artifacts.



Sub-Processes - {

SUB-PROCESSES

- o Very concrete jobs with specifiable low level data inputs and outputs.
- o Taken as low as necessary to define work completely

BUILDING BLOCKS

- o Fundamental kinds of work.
- o For most part unaffected by context.
- o Starting point for process definition.

Upper Level Dataflows

FIGURE 5
Page 1132

Structure of IPD Process

o Interfaces at every level to connect with the rest of engineering
o Procedures & Requirements decomposed too.

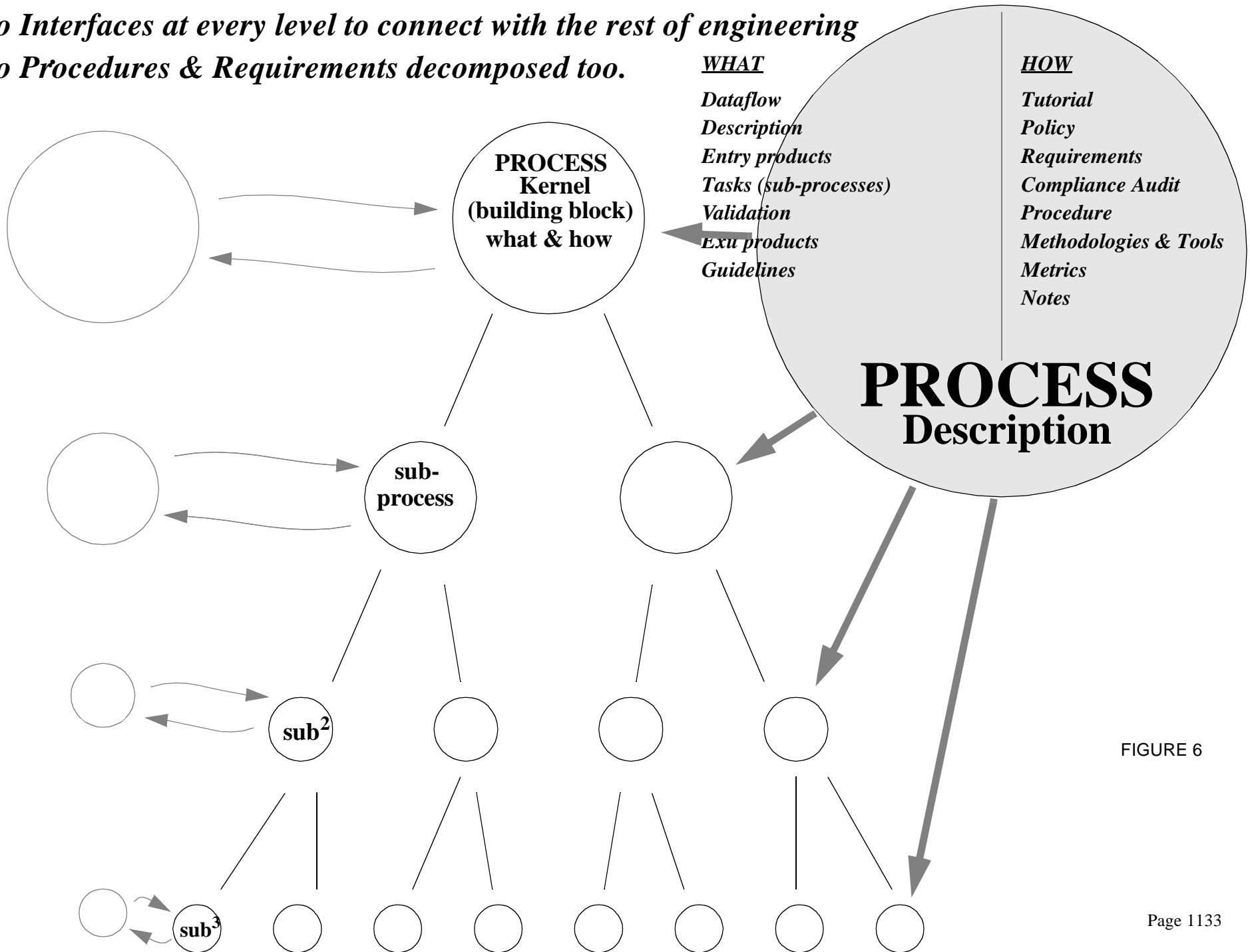
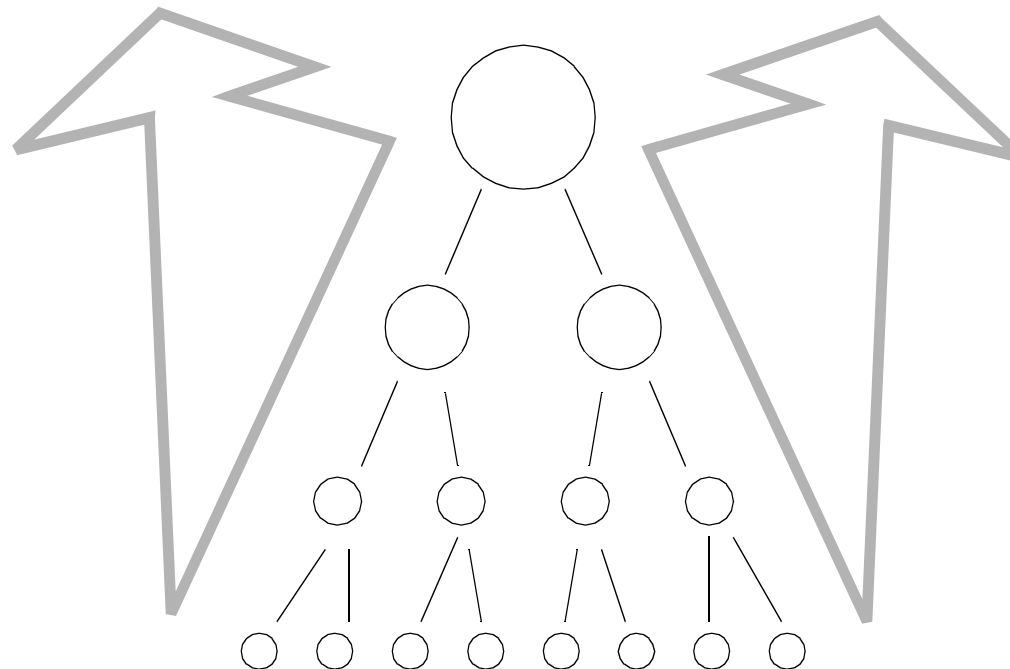
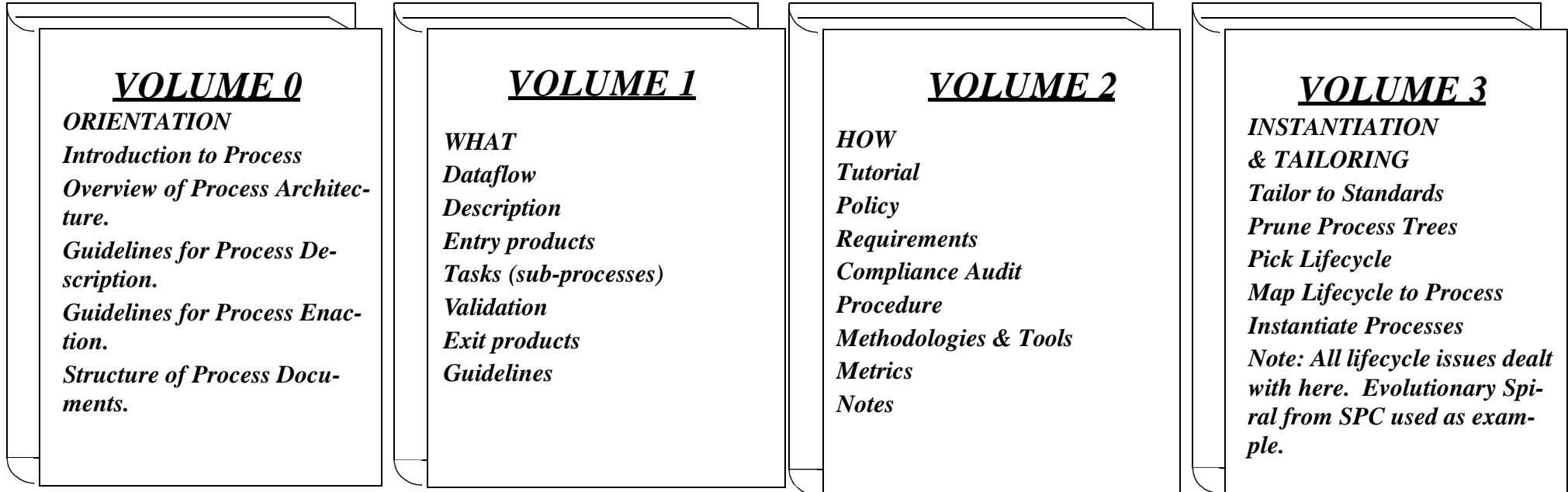

FIGURE 6

Structure of Process Document



o A single structure unites two volumes

FIGURE 7

FACETED RESOLUTION OF INTERFERENCE

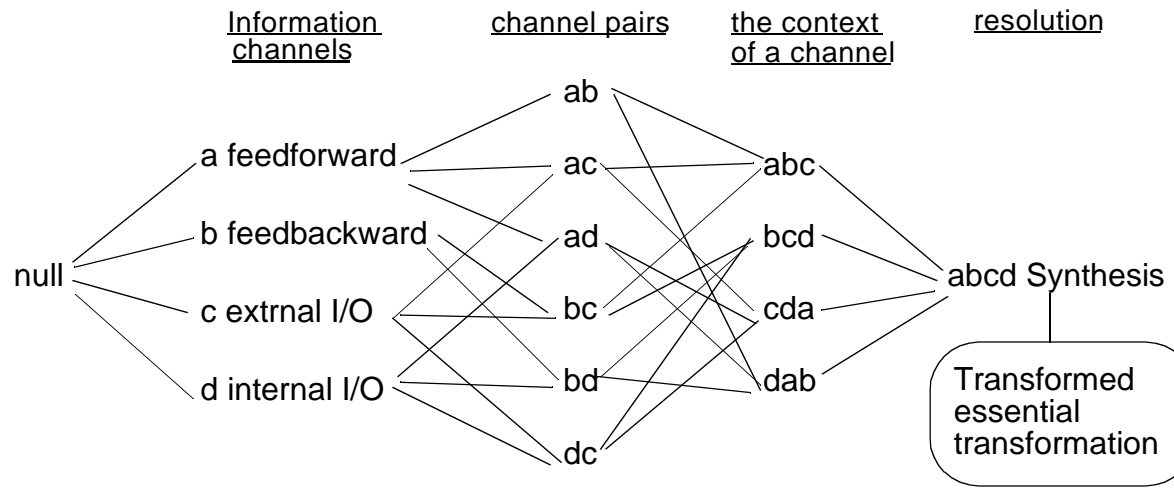

FIGURE 9

INTERFACES OF AUTOPOIETIC RING

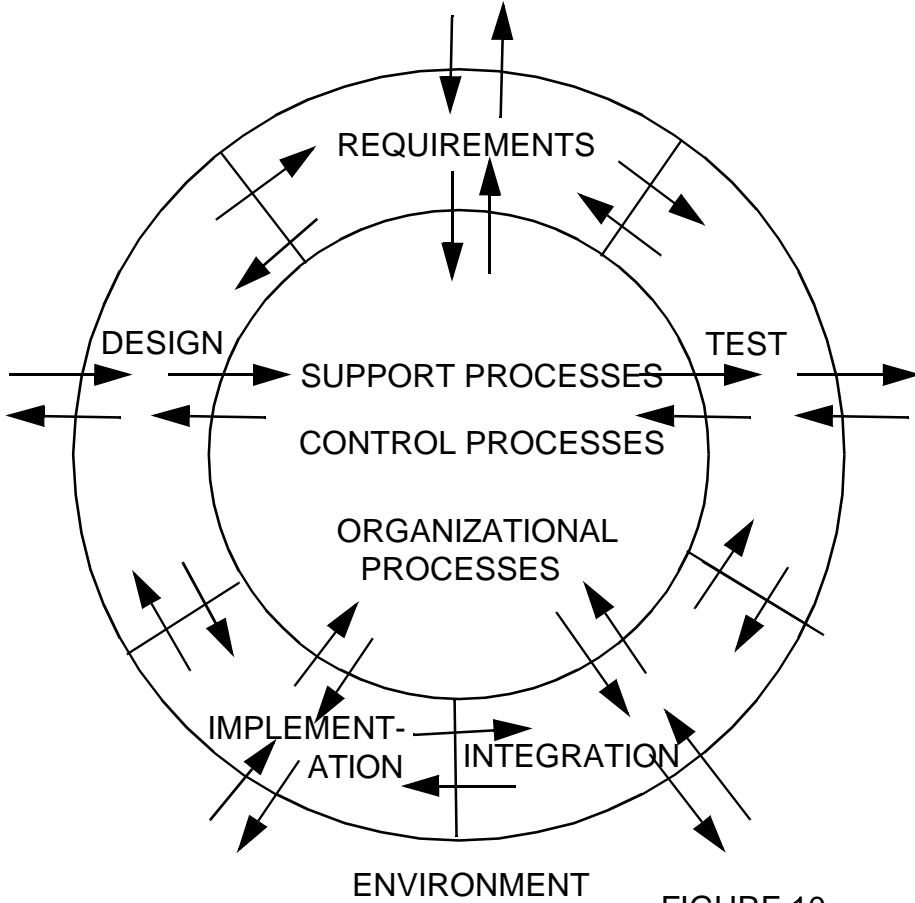

FIGURE 10

EXAMPLE DATA FLOW THROUGH RING

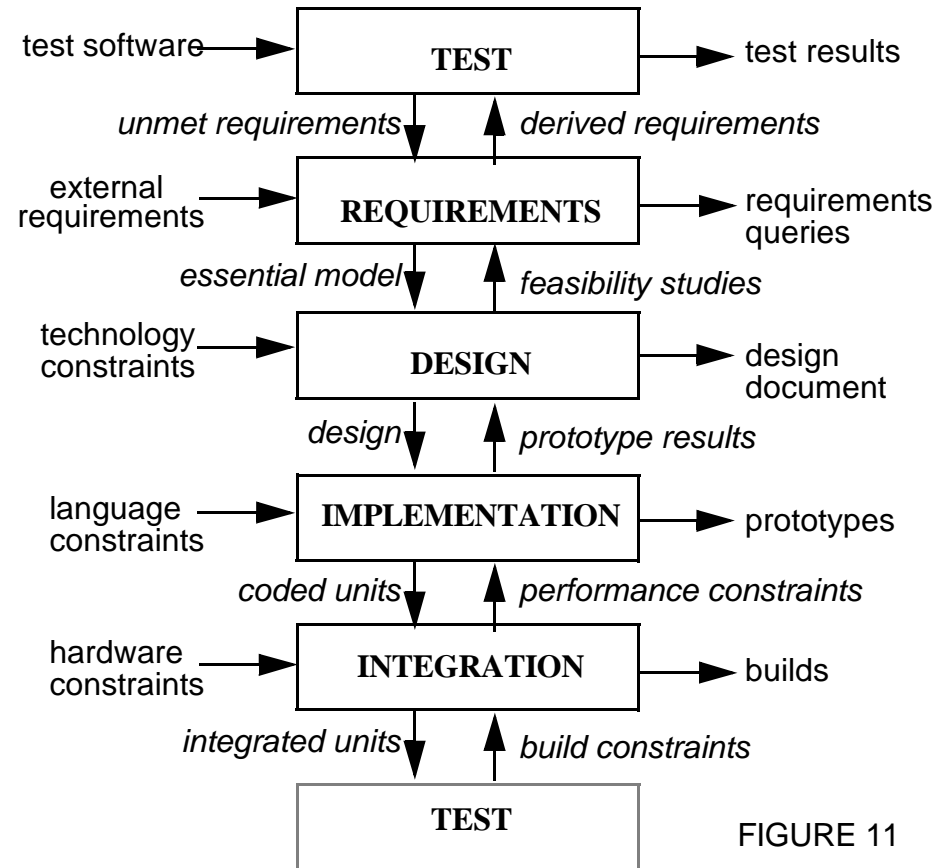

FIGURE 11

INTERACTIONS OF AUTOPOIETIC RING

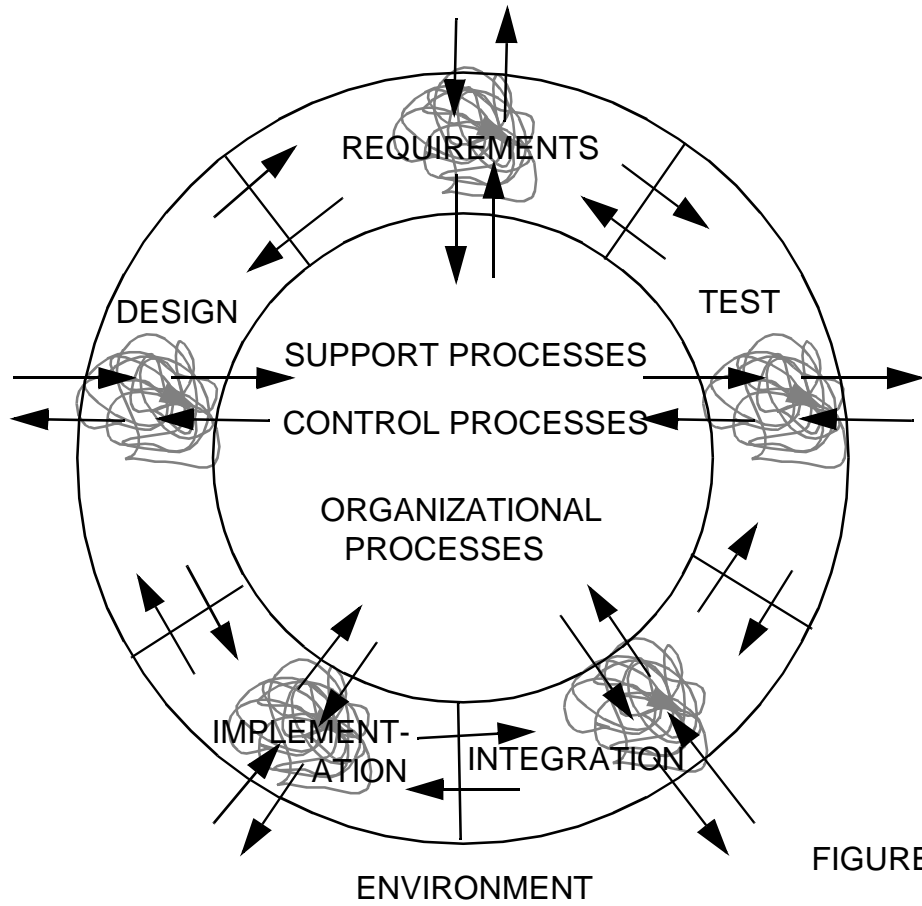

FIGURE 12

INTERFERENCE NODE

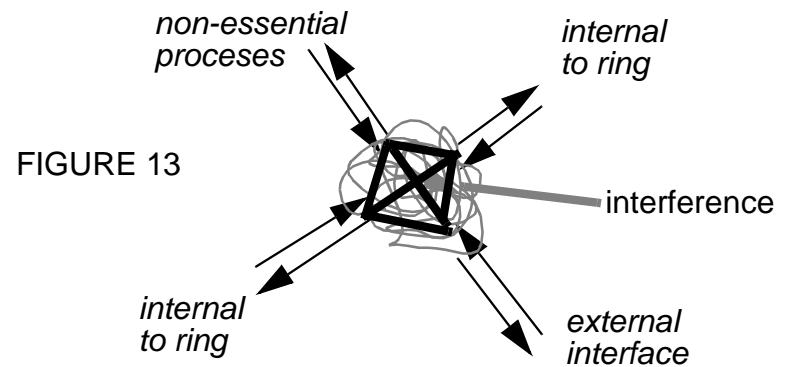

FIGURE 13

RESOLUTION OF KINDS OF WORK IN RING

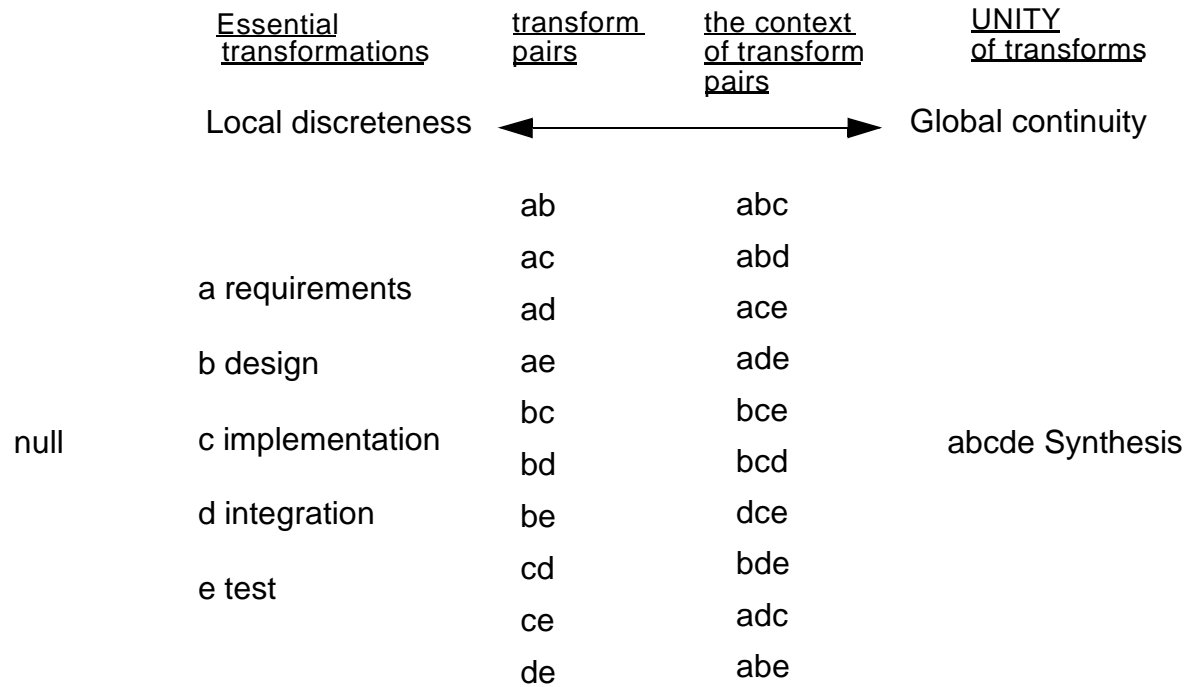
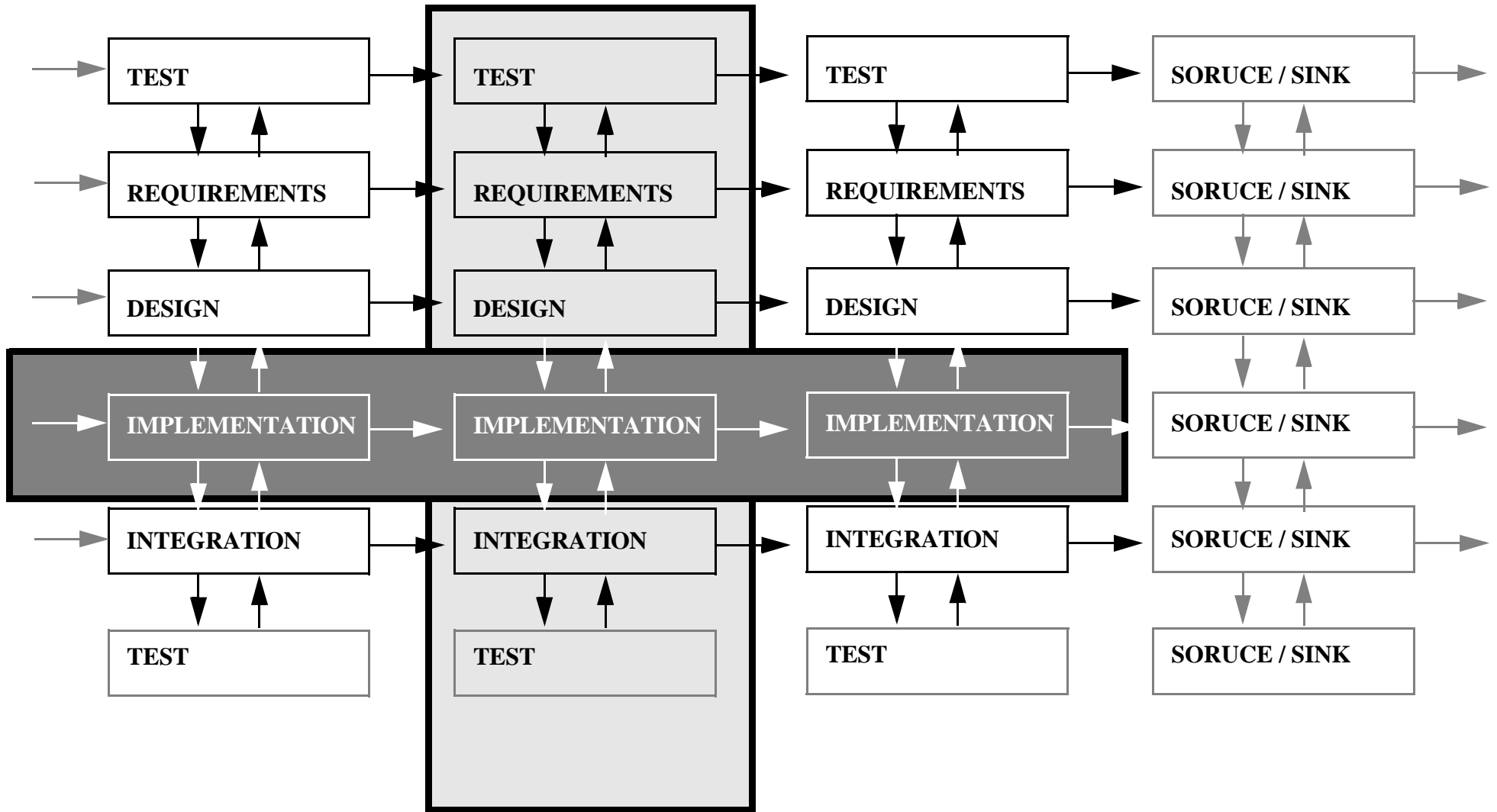

FIGURE 14

META-RING OF STACKED AUTOPOIETIC RINGS



TWO DIMENSIONS OF PROCESS COORDINATION

FIGURE 16

PROTOTYPE LIFECYCLE

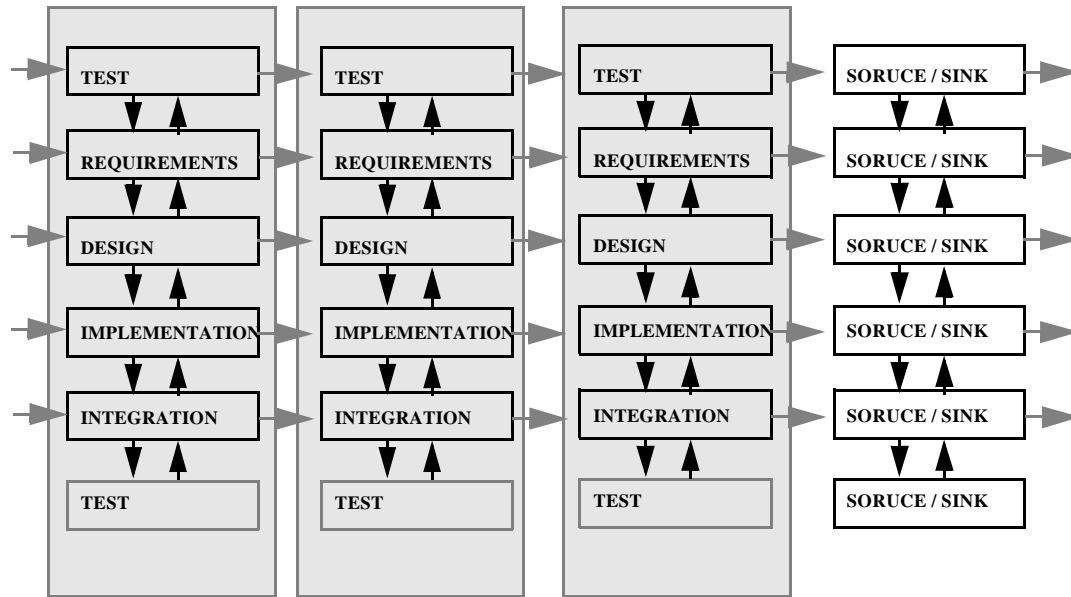

FIGURE 17

Spiral Model combines both prototyping and waterfall lifecycles additively

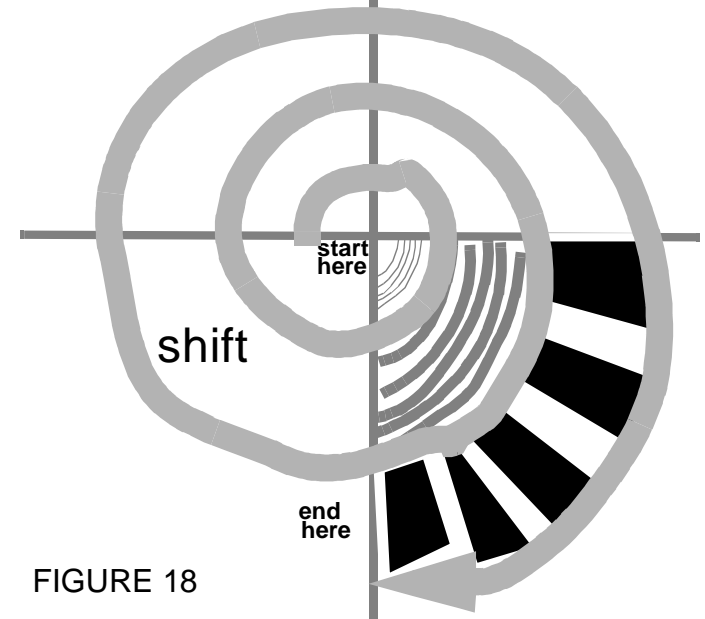

FIGURE 18

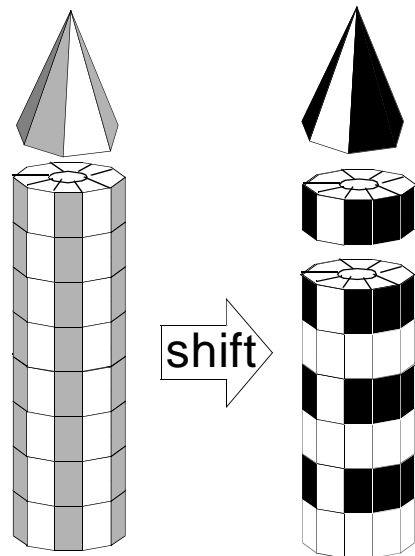

FIGURE 19

WATERFALL LIFECYCLE

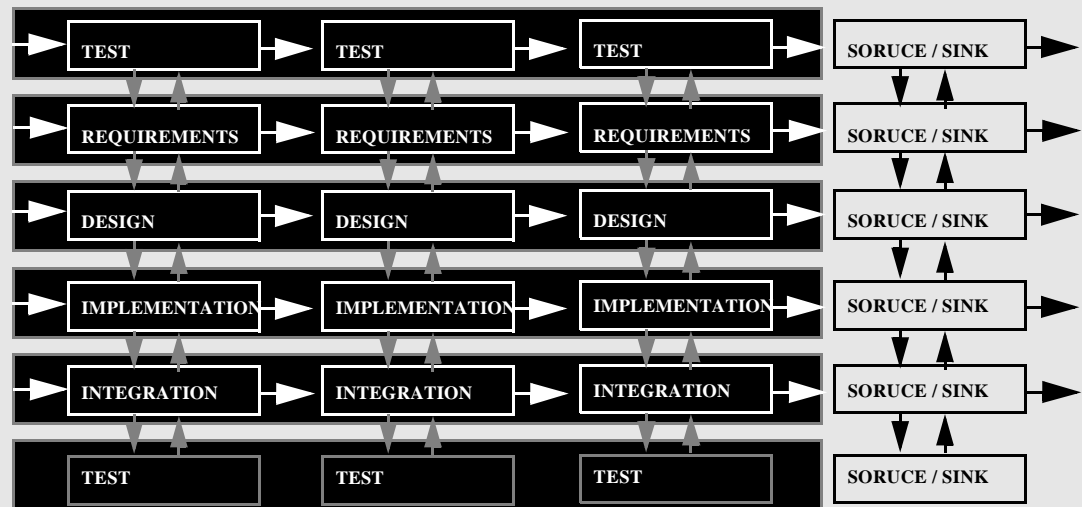

FIGURE 20

AUTOPOIETIC HYPER-CYCLE

INTERSUBJECTIVE

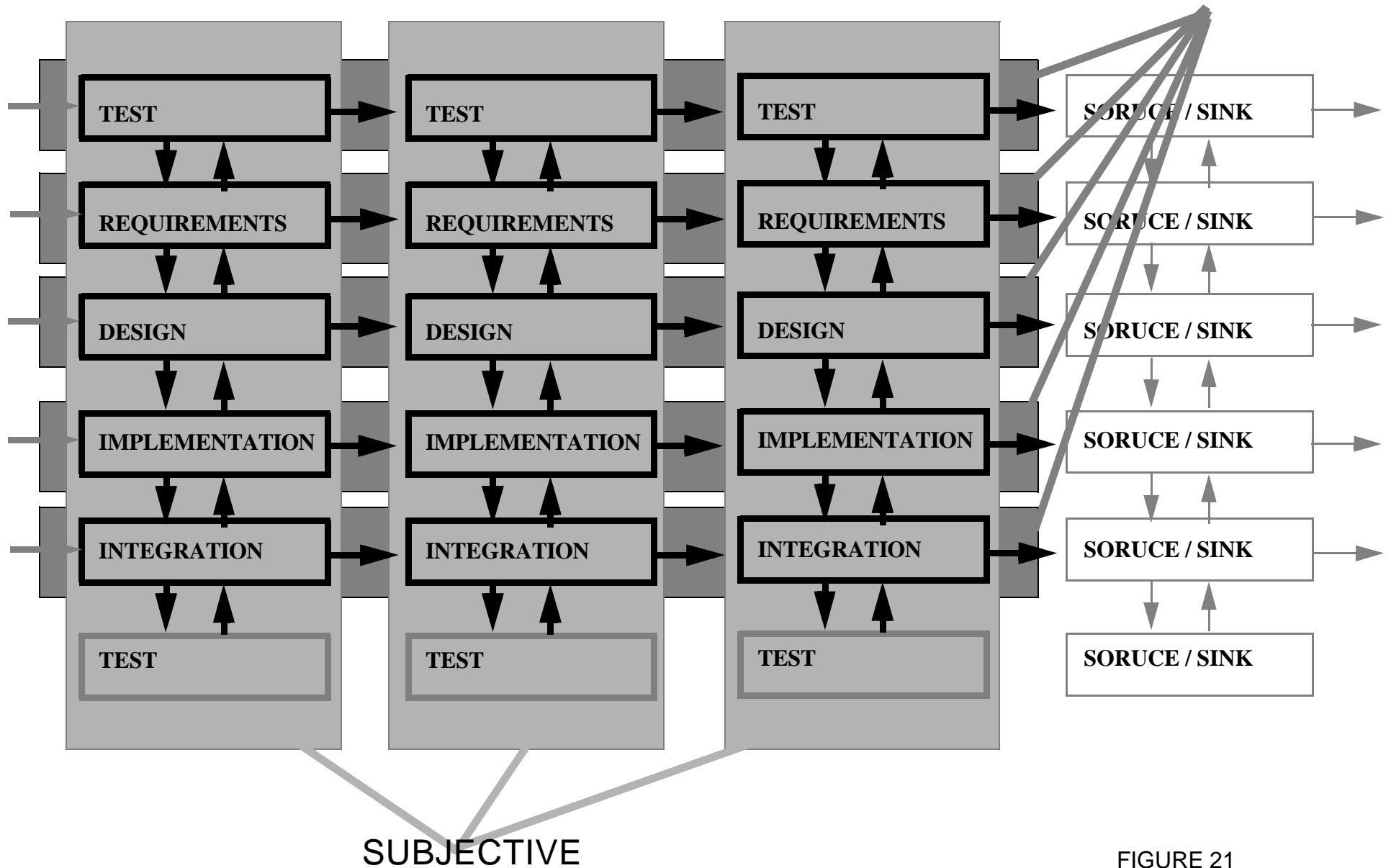

FIGURE 21

Keeps subjective autopoietic rings and at same time has intersubjective meta-ring structure.

AUTOPOIETIC HYPER-CYCLE

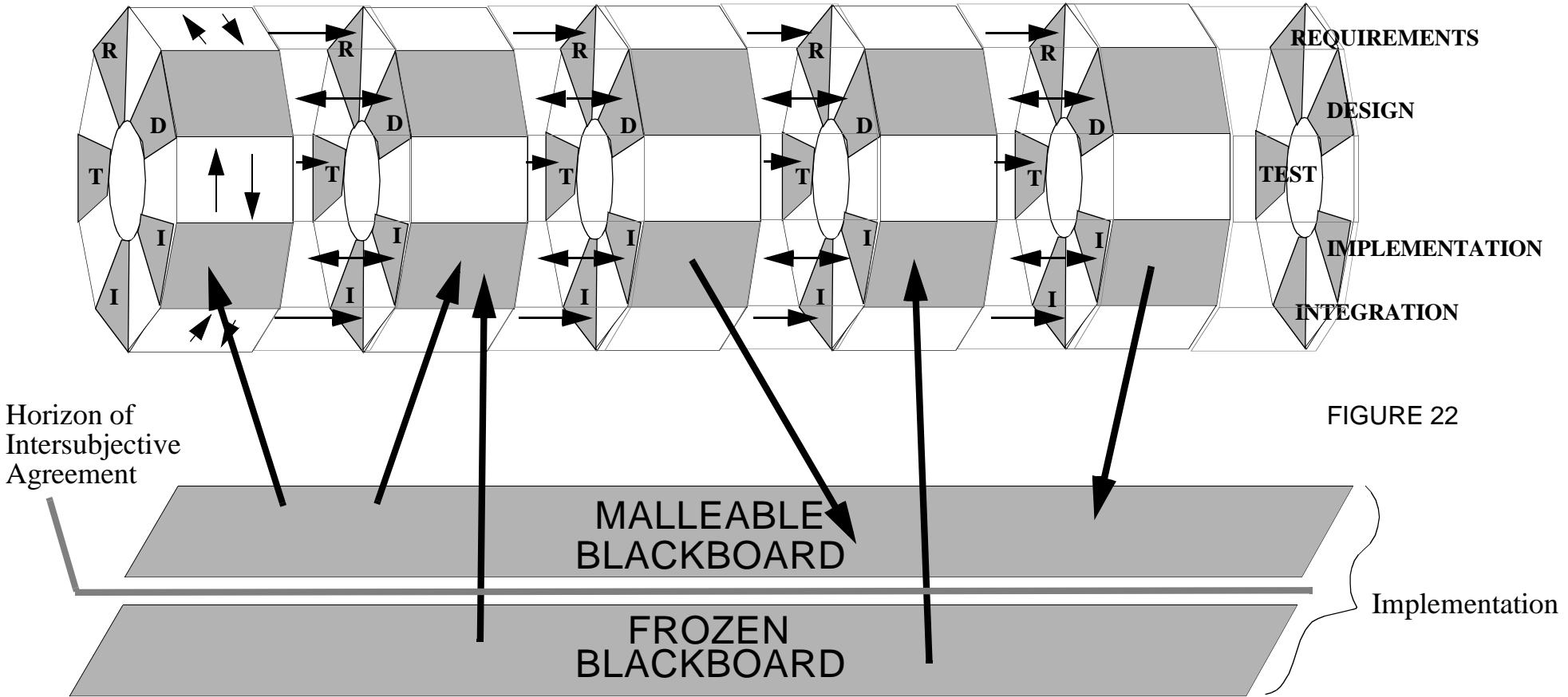

FIGURE 22

The concept of the autopoietic hypercycle is to allow each individual to operate semi-independently while participating in overall formalized communications. Each autopoietic ring would follow the timewarp analogy, forge ahead with their own work, communicating as much as possible with others via well-defined interfaces. The results of the work would be written out to a global blackboard which would be divided into malleable and frozen areas. The independent agents would read the blackboard and see where the overall design is and what has changed in other areas. The frozen area would be what aspects of the system were intersubjectively agreed upon. This horizon is the actual global present which individual agents may be outstripping. This means they may have to do some rework if the frozen design happens to turn out differently than expected by that agent. The agent would watch the horizon between frozen and malleable aspects of the system, carefully taking risks as to where to go ahead on and where to wait for intersubjective agreement. The outer wheel of blackboards corresponding to each essential process allows intersubjective waterfall-like coordination while the inner hub of stacked autopoietic rings allows the strongest possible coherence throughout the development process. The inner rings and the outer wheel are connected by the concept of mutually accessible blackboards using the time-warp system which allows global time to lag behind the time of independent agents. This may involve some rework, but the process is designed to minimize this and allow for moving ahead on individual pieces while others lag behind.

INTERFACES OF AUTOPOIETIC RING

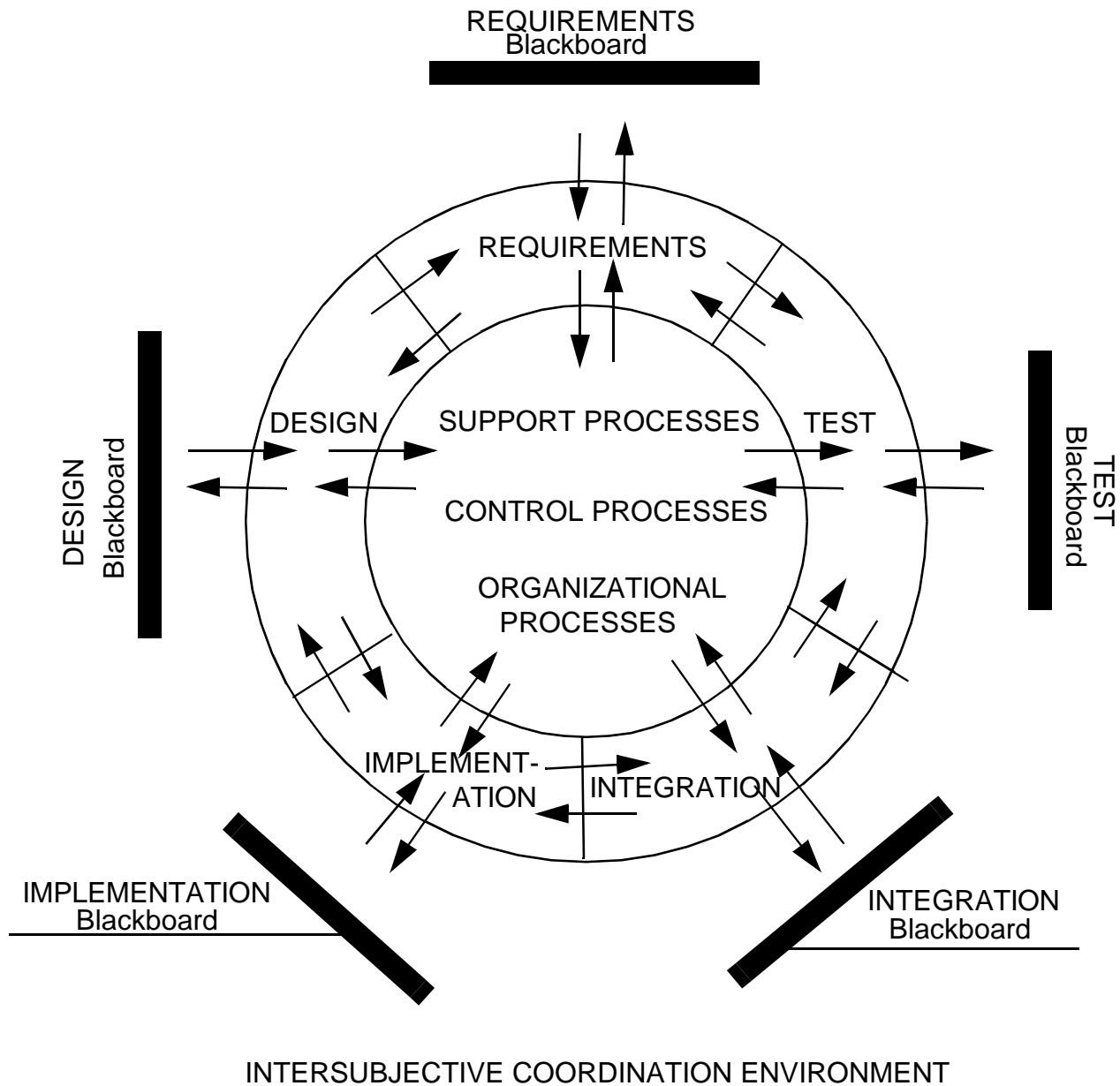

FIGURE 23

Personal Process Notes

Process Name: *A-process*

Guidance:

Name:

Start Date:

End Date:

Reference: #

Formal process description, if any.

Inputs:

Identify known inputs to process.

Outputs:

Identify known outputs to process.

Steps:

Identify known steps in process.

Issues:

Identify known issues that arise in process.

Notes:

FIGURE 24

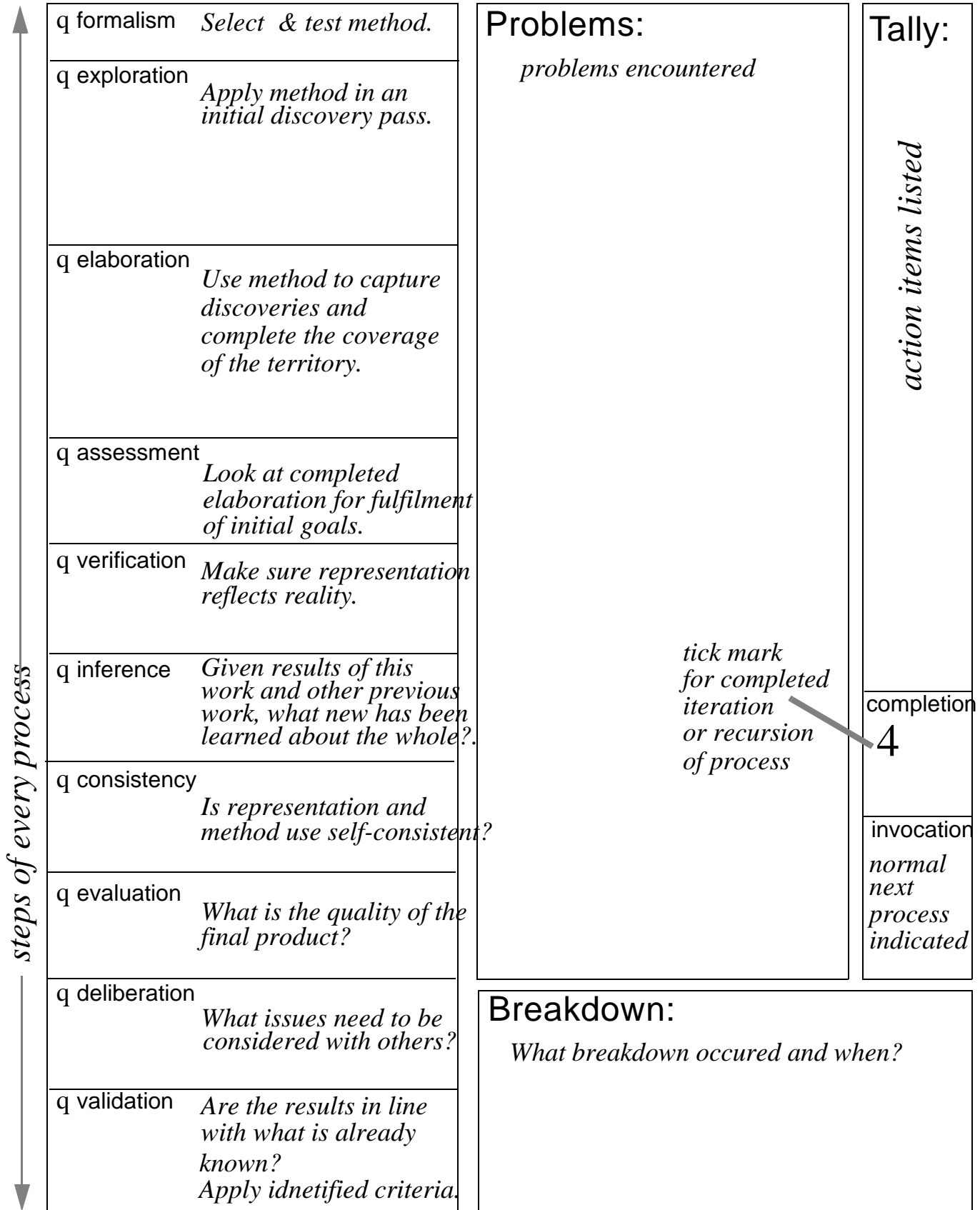

FIGURE 25

Personal Process Planning

Name:

Start Date:

Reference:

End Date:

Concurrent Processes:

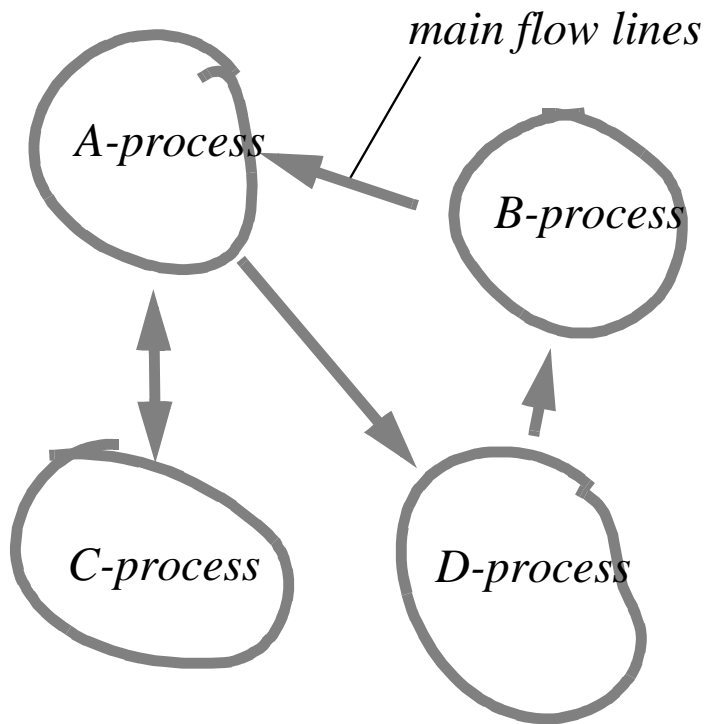

Work Assignments:

1 -- assignment

2 -- assignment

3 -- assignment

Interrupts:

source -- subject

FIGURE 26

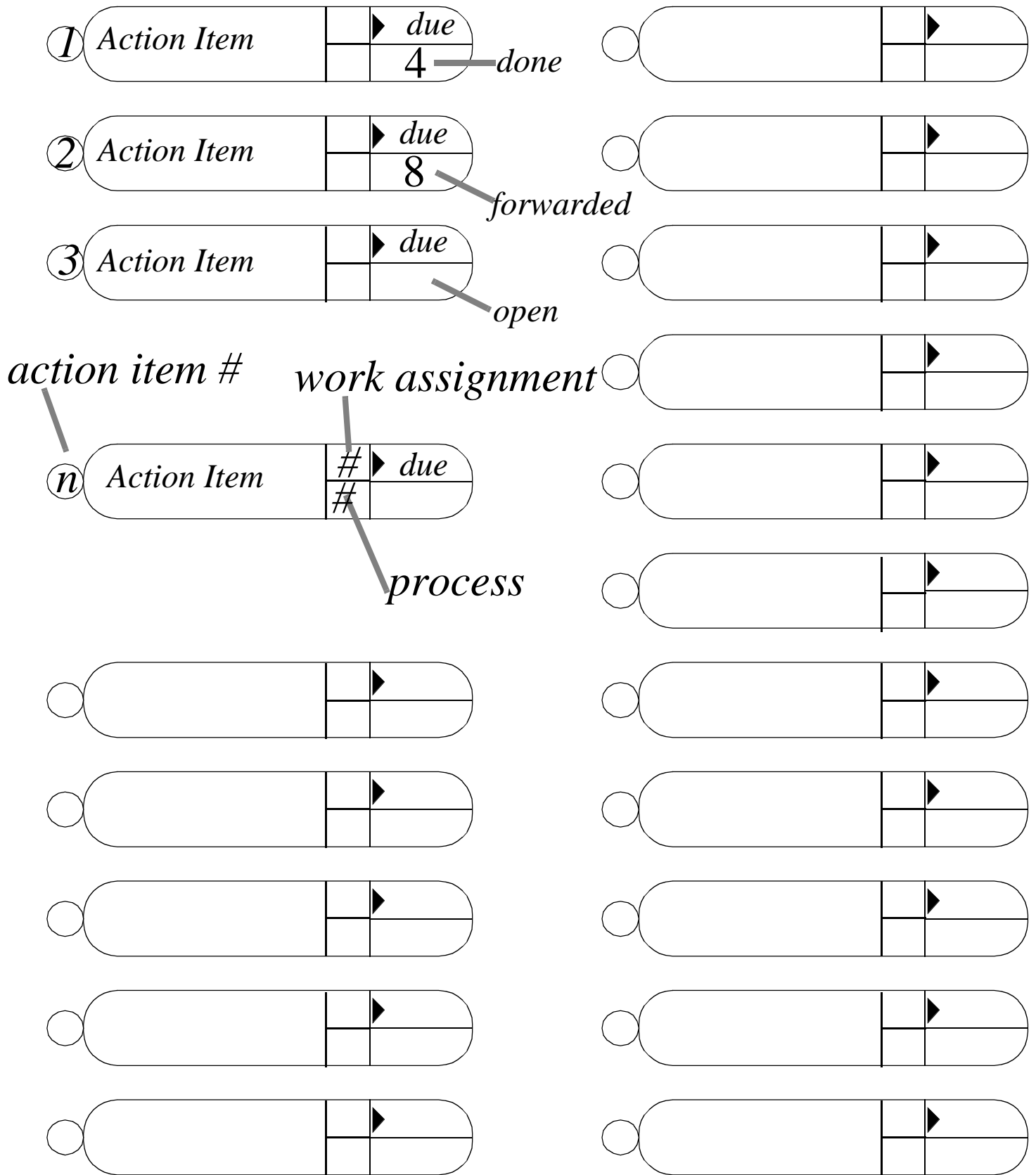

FIGURE 27

Five phases derived from design viewpoints plus one.

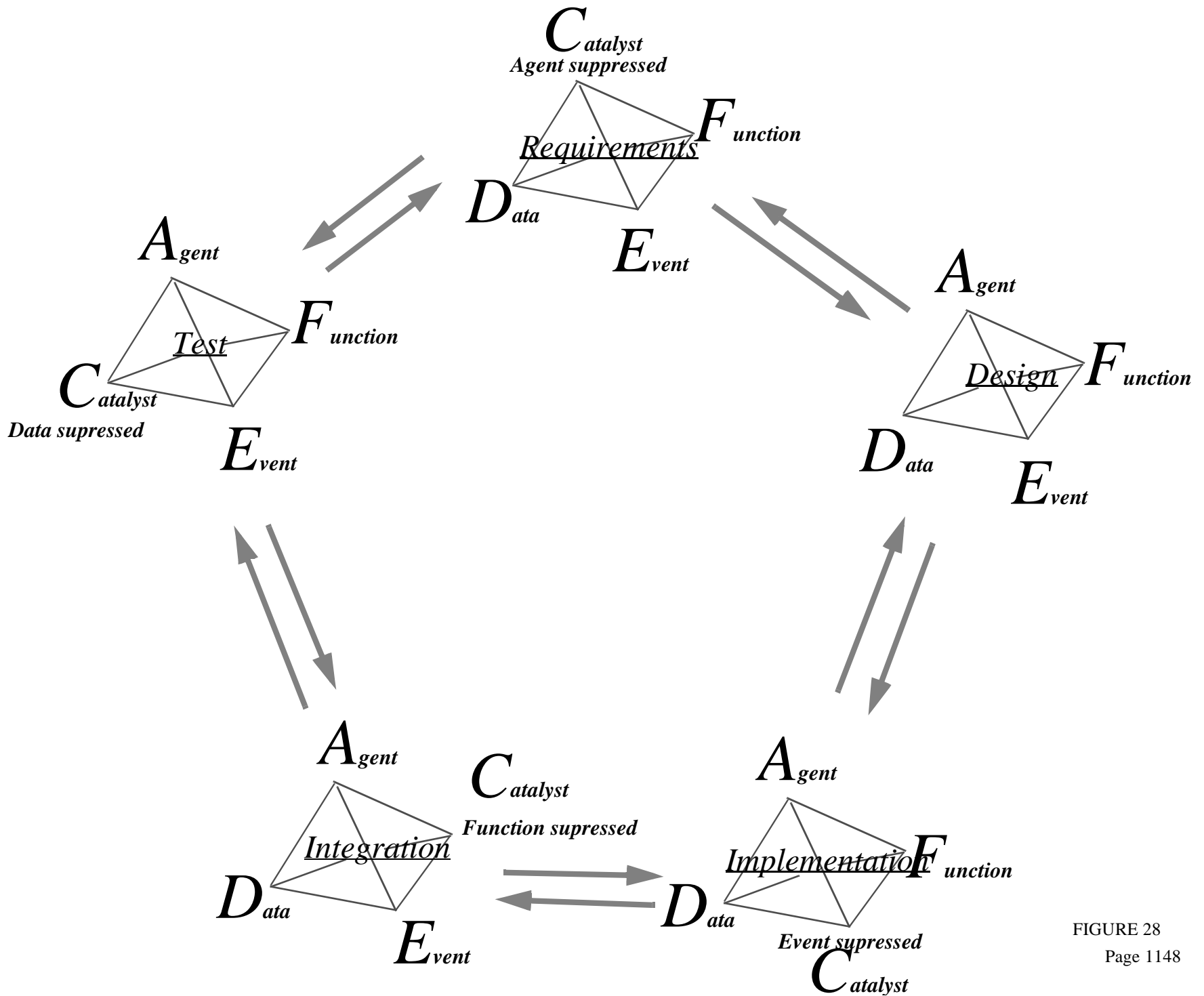
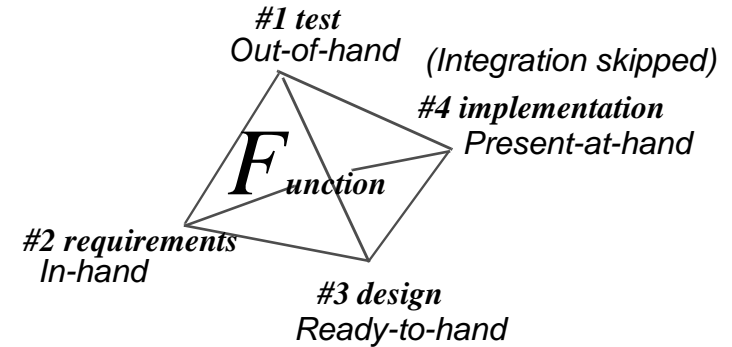
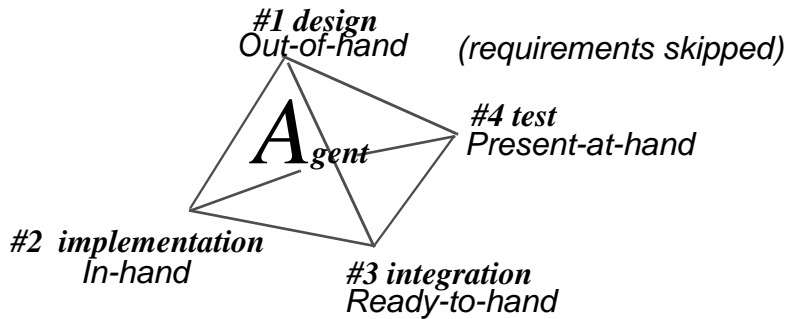
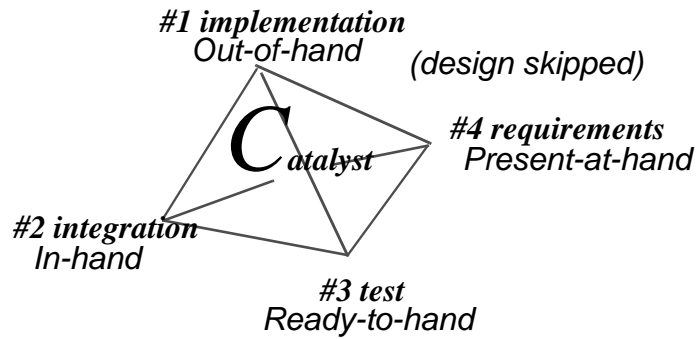

FIGURE 28
Page 1148

Five viewpoints:

Each has its own independent lifecycle. One would expect a different modality of Being to be emphasised in each phase of these mini-lifecycles.



KIND OF BEING	MODALITY
Pure Presence	Present-at-hand
Process Being	Ready-to-hand
Hyper-Being	In-hand
Wild Being	Out-of-hand

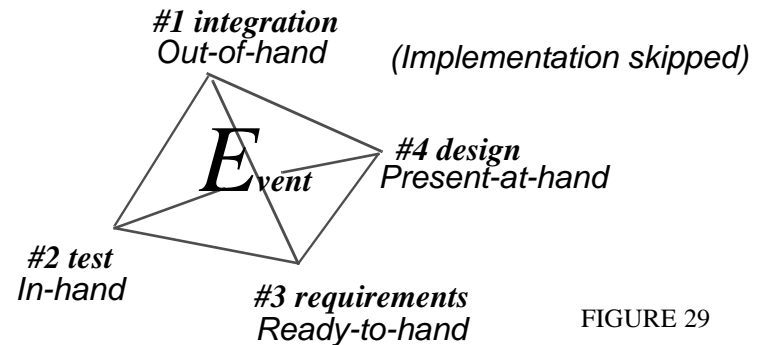
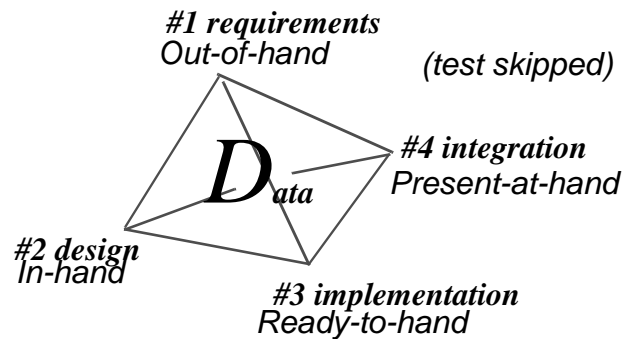

FIGURE 29

FIVE HSING

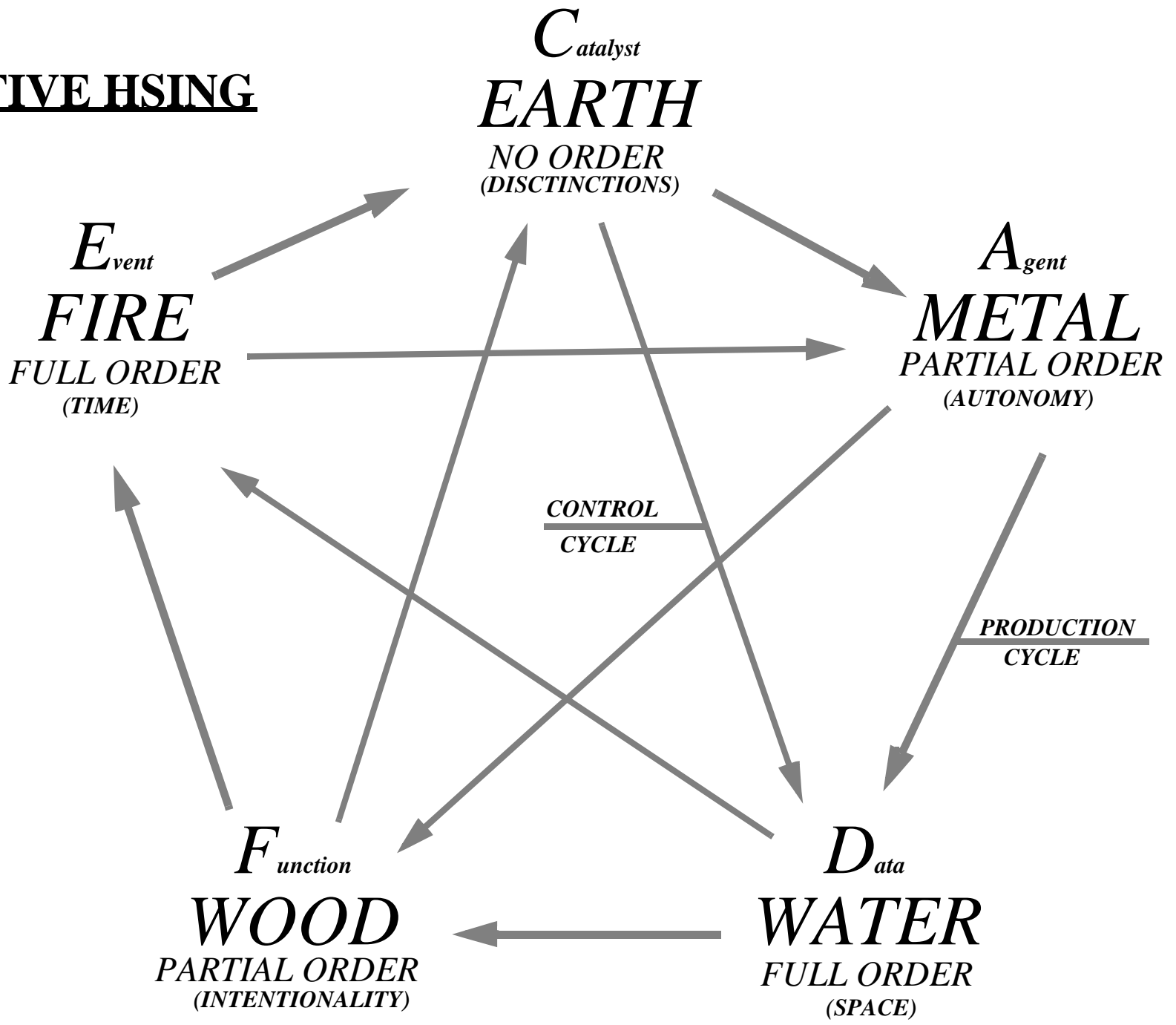

FIGURE 31

Possible Minimal Methods associated with the Catalytic viewpoint

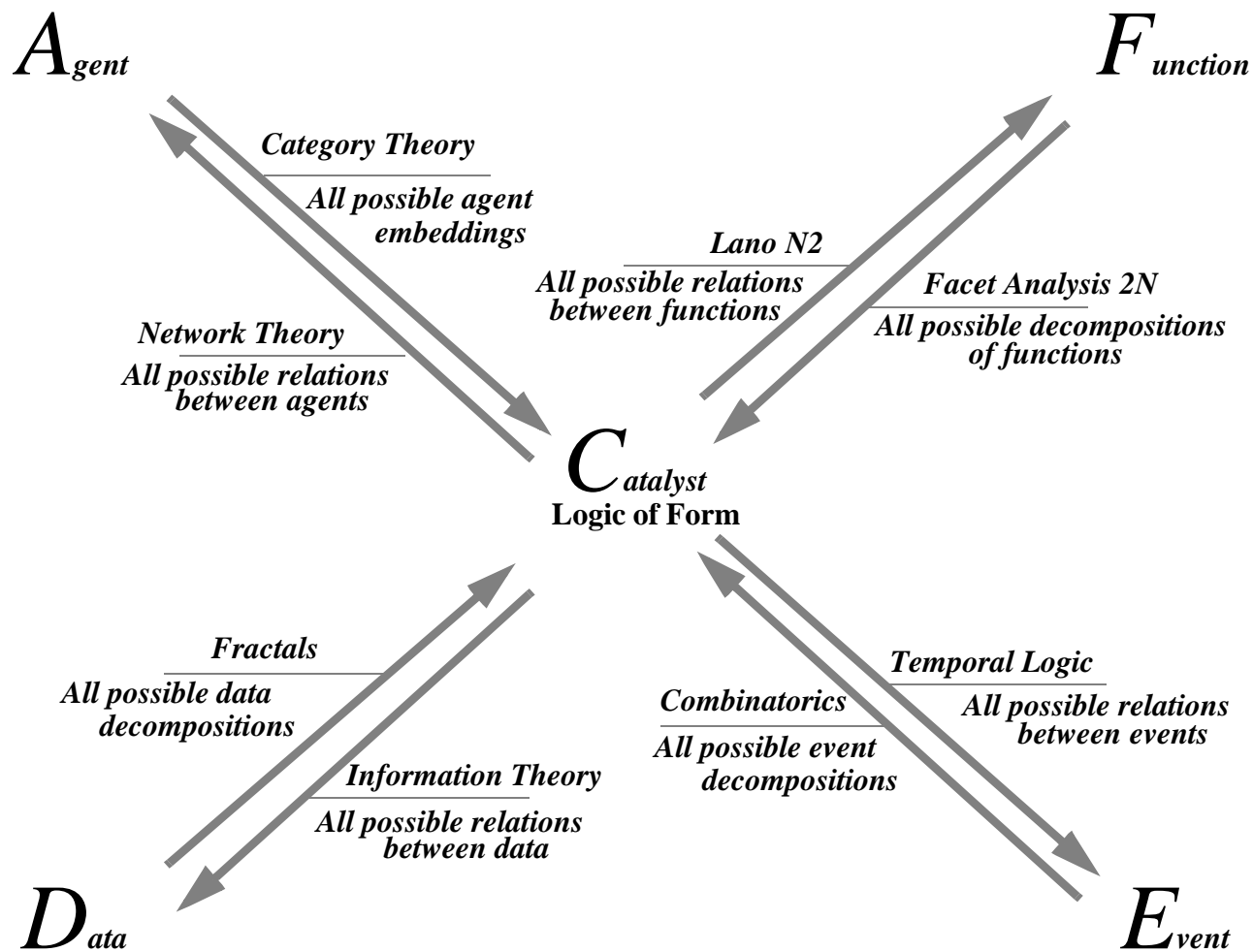

FIGURE 30

FOUR FACES OF EVERY MINIMAL SYSTEM

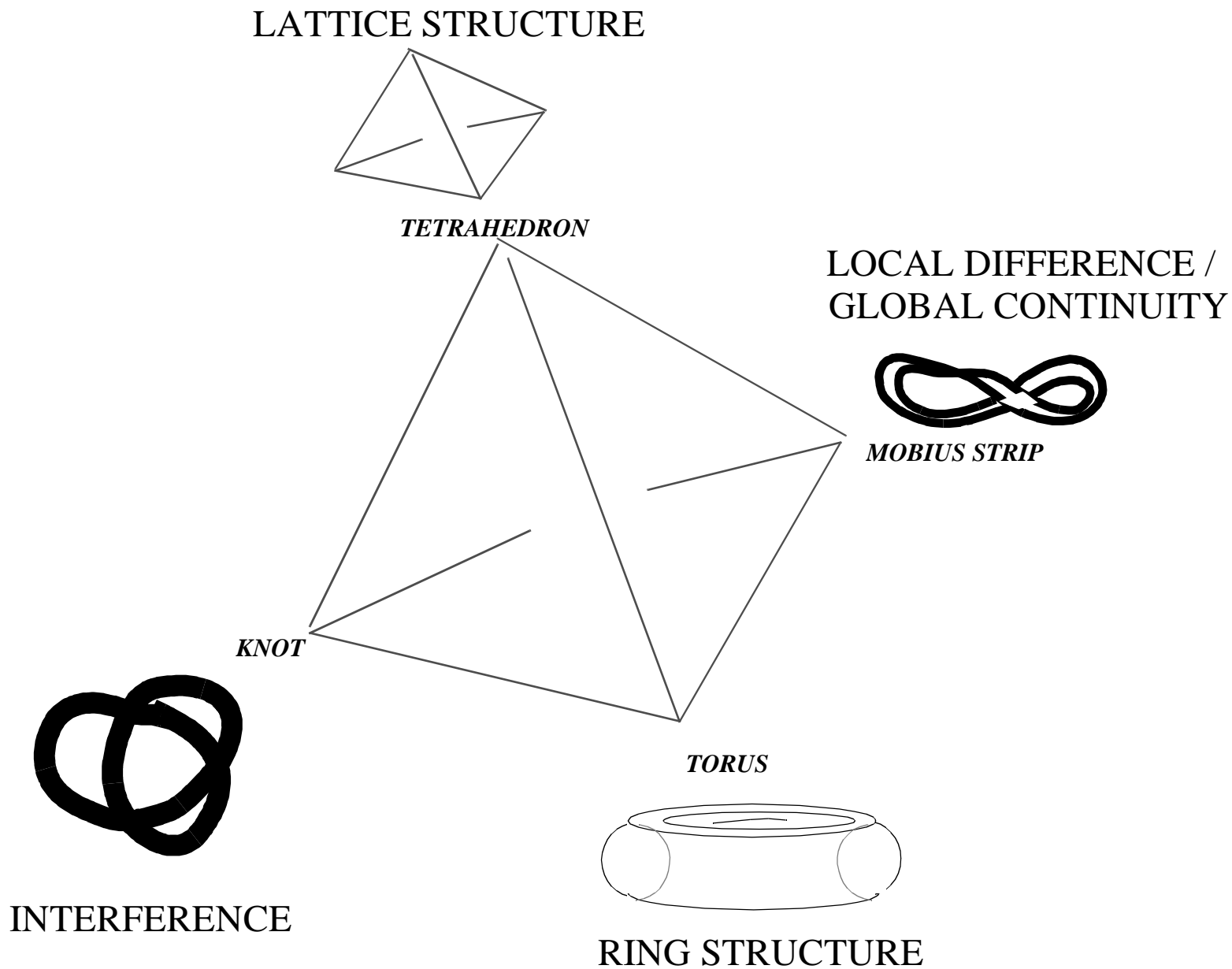

FIGURE 32
Page 1152

Apeiron Press

PO Box 4402
Garden Grove,
California 92842-4402

714-638-7376
714-638-1210
palmer@think.net
palmer@netcom.com
palmer@exo.com
Dateline 714-638-0876

Copyright 1996 by Kent Duane Palmer

Draft #1 950710 Editorial Copy.
Not for distribution.

All rights reserved. No part of this book may be reproduced in any form or by any means, electronic or mechanical, including photocopying, recording, or by any information storage and retrieval system, without permission in writing from the publisher.

This book was set using Framemaker document publishing software by the author.

Electronic Version in Adobe Acrobat PDF available at <http://server.snni.com:80/~palmer/homepage.html>

Library of Congress
Cataloging in Publication Data

Palmer, Kent Duane

WILD SOFTWARE META-SYSTEMS

Bibliography
Includes Index

1. Philosophy-- Ontology
2. Software Engineering
3. Software Design Methods

I. Title

[XXX000.X00 199x]
9x-xxxxx
ISBN 0-xxx-xxxxx-x

Keywords:

Software, Design Methods, Ontology,
Integral Software Engineering
Methodology, Systems Theory